



Power Flow Control In Induction Motor By Using A Symmetrical Multilevel Inverter

Vani Mishra

Student, M.E In Power Electronics, NRI INSTITUTE OF INFORMATION SCIENCE
& TECHNOLOGY College, RGPV Universtiy, Bhopal, India

Abstract:

The Assymetrical multilevel inverter topology is used for the optimization of levels with a minimum no. of voltage sources. It is used where medium voltage and higher power is required. There are three or four H-bridge of single phase inverter (consist of MOSFET or Optocoupler) connected to Induction motor. All H-Bridges are working with different vottage sources bases on the G.P ratio(2or3). A multilevel inverter is more advantageous in comparison with a conventional two-level converter that uses high switching frequency pulse width modulation(PWM). The increase in the number of level in multilevel inverter reduces the total harmonic distortion (THD), common mode voltages, the output filters and the switching losses and hence power flow can be controlled by providing smooth a.c sine wave to the induction motor to mainly prevent the reduction of the efficiency of the motor due to harmonics which are present in normal power supply. But in multilevel there are also some limitations if we will go for higher levels i.e. beyond 27 level that we will also see here in detail description by the results of simulation done on MATLAB7.10.

Keywords: *Assymetrical multilevel inverter, MOSFET, Optocoupler, Induction motor, H-Bridge (consist of MOSFET), G.P ratio, Conventional two-level converter, PWM, THD, common mode voltages, output filters, switching losses, harmonics, ac sine wave, efficiency, simulation*

1.Introduction

Numerous industrial applications have begun to require higher power application in recent years. Some medium voltage motor drives and utility applications require medium voltage motor drives and utility applications require medium voltage and megawatt power level. For a medium voltage grid, it is troublesome to connect only one power semiconductor switch directly. As a result a multilevel power converter structure has been introduced as an alternative in high power and medium voltage situation. A multilevel converter not only achieves high power ratings, but also enables the use of renewable energy sources. Renewable energy sources such as photovoltaic, wind and fuel cells can be easily interfaced to a multilevel converter system for a high power application.

The concept of multilevel converters has been introduced since 1975. The elementary concept of multilevel converter to achieve higher power is to use a series of power semiconductor switches with several lower voltage d.c sources to perform the power conversion by synthesizing a stair case voltage waveform. Capacitors, batteries and renewable energy voltage sources can be used as the multiple d.c voltage sources.

Multilevel inverter topologies can work at higher voltage and higher power than conventional two level converter. A multilevel converter has several advantage over a conventional two level converter that uses high switching frequency pulse width modulation (PWM).

The attractive features of a multilevel converter can be briefly summarized as follows:

- Staircase waveform quality:
Multilevel converters not only can generate the output voltage with very low distortion, but also can reduce the dv/dt stresses; therefore electromagnetic compatibility problem can be reduced.
- Common mode voltage (CM):
Multilevel converters produce small CM voltage; therefore, the stress in the bearings connected to a multilevel motor drive can be reduced. Furthermore, CM voltage can be eliminated by using advanced modulation strategies such as that proposed in.
- Input current: Multilevel converters can draw input current with low distortion.

- Switching frequency: Multilevel converters can operate at both fundamental switching frequency and high switching frequency PWM. It should be noted that lower switching frequency usually means lower switching loss and higher efficiency.

Due to above feature we are using a multi level for power control of induction motor.

- One particular disadvantage is the greater number of power semiconductor switches needed.
- Although lower voltage rated switches can be utilized in a multilevel converter, each switch requires a related gate drive circuit. This may cause the overall system to be more expensive and complex.

2. Two Types Of Multilevel Inverter

- Symmetrical type Multilevel Inverter
- Asymmetrical type Multilevel Inverter

In symmetrical multilevel inverter, all H-bridge cells are fed by equal voltages and hence all the arm cells produce similar output voltages.

If all the cells are not fed by equal voltages, the inverter becomes an asymmetrical one. In this inverter, the arm cells have different effect on the output voltage.

The cascade H-Bridge inverter consists of power conversion cells, each supplied by an isolated dc source on the dc side, which can be obtained from batteries, fuel cells, or ultra capacitors and series connected on the a.c side.

Fig1 shows a one phase circuit for a machine drive using 3 cascade H-bridge inverter consist of MOSFETS.

If we will provide voltage 1Vdc, 1Vdc, 1Vdc with G.P ratio 1 to the three H-bridge then the simulation output will be as shown in the Fig2. It is called 7 level symmetrical output of as we are providing symmetrical

voltages. $V_{0,1}(t)=1Vdc$, $V_{0,2}(t)=1Vdc$, $V_{0,3}(t)=1Vdc$ shows the output waveform of the individual bridge and $V_0(t)=3Vdc$ shows the summation of above 3 waveforms.

If we will provide voltage 1Vdc, 2Vdc, 4Vdc, with G.P ratio 2 to the three H-bridge then the total simulation output $V_0(t)=15Vdc$ will be as shown in Fig3(d). It is called 15 level symmetrical output as we are providing asymmetrical voltages. $V_{0,1}(t)=1Vdc$, $V_{0,2}(t)=2Vdc$, $V_{0,3}(t)=4Vdc$ shows the output waveform of individual bridge as shown in Fig3(a), Fig3(b), Fig3(c) respectively.

An output phase voltage waveform is obtained by summing the bridges output voltages.

$$V_0(t) = V_{0,1}(t) + V_{0,2}(t) + \dots + V_{0,N}(t) \quad (1)$$

Where N is the number of cascaded bridges.

Again, if all dc voltage sources in Fig1 are equal to V_{dc} , the inverter is then known as a symmetric multilevel. And if all dc voltage sources are not equal it is called Asymmetrical multilevel inverter.

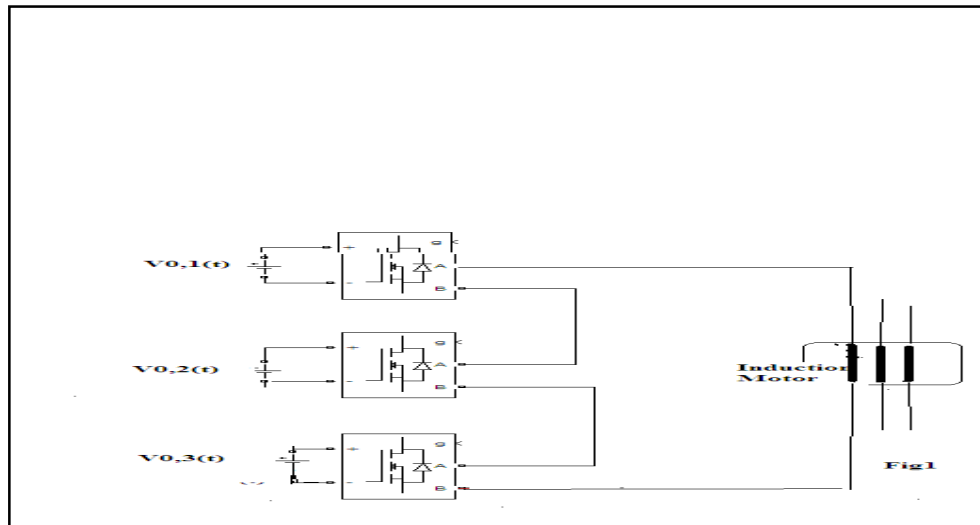

Figure 1

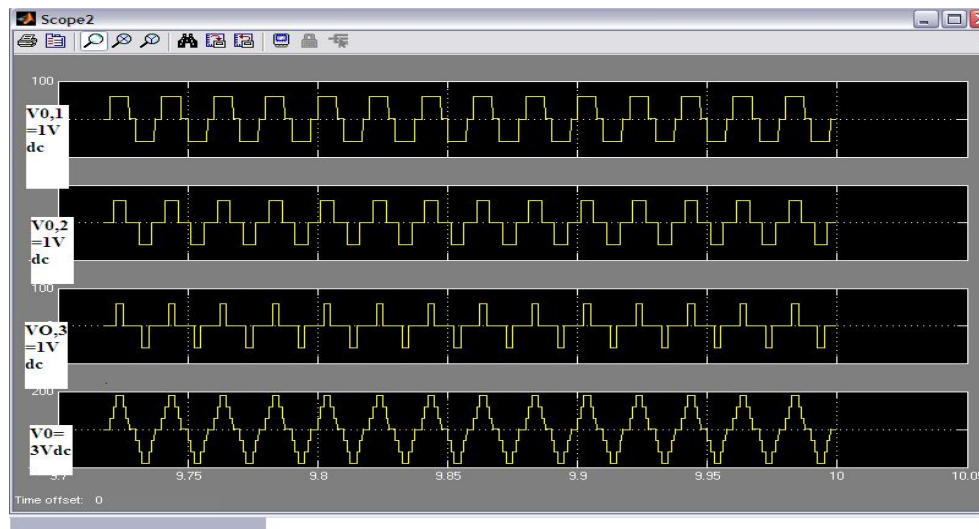

Figure 2

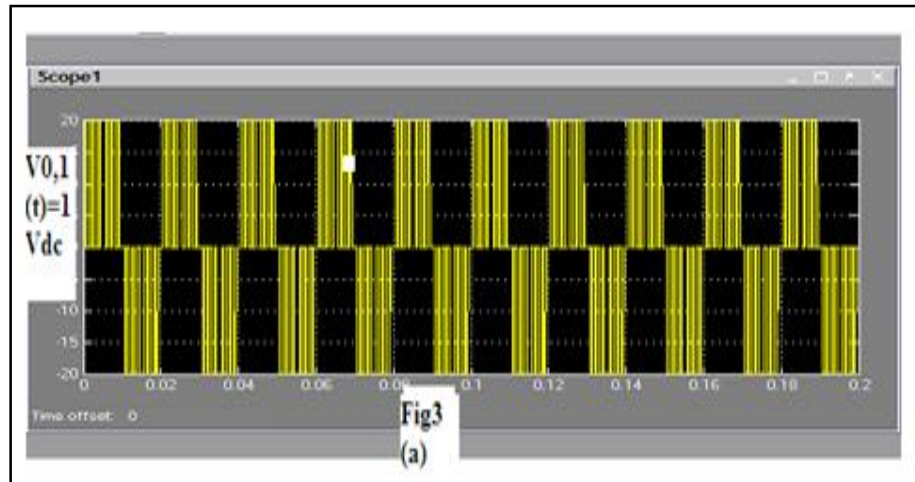

Figure 3(a)

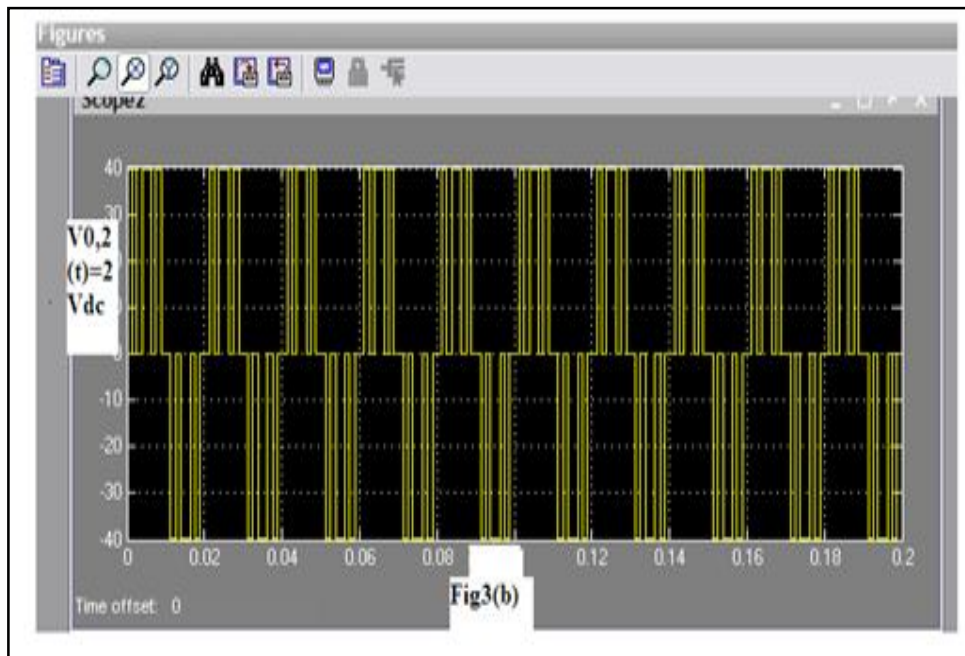

Figure 3 (b)

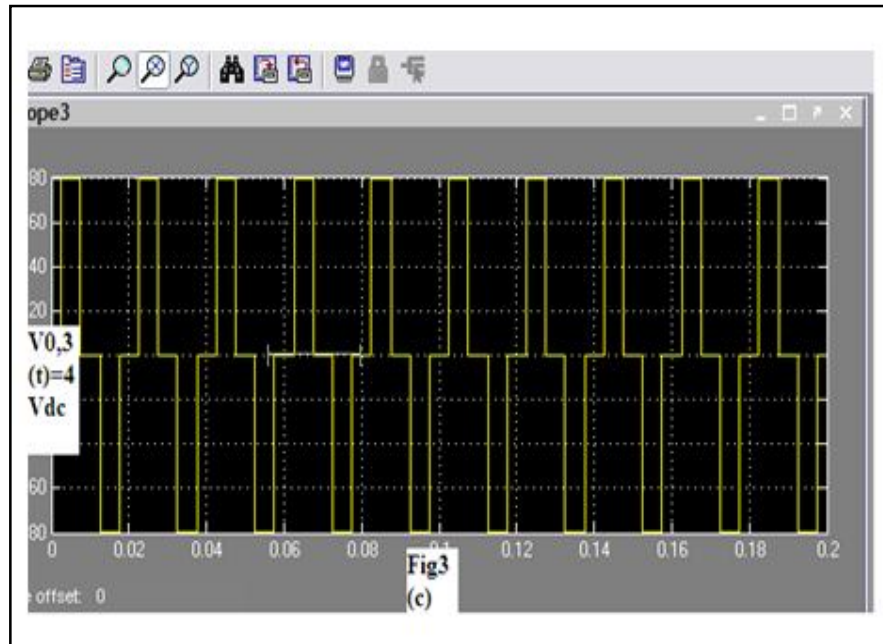

Figure 3(c)

2.1. Advantages Of Asymmetrical Type Multi Level Inverter

- The main advantage of asymmetrical multilevel inverters is the optimization of levels with a minimum number of power supplies.
- The increase in the number of voltage levels reduces the total harmonic distortion (THD), the common-mode voltages, the output filters, and the switching losses.
- The main bridges, which carry 80% of the total power, work at a very low frequency.
- In some particular operation it can be operated with a single dc source.
- It enables the use of the Renewable Power Sources.

2.2. Disadvantages Of Asymmetrical Type Multi Level Inverter

- They need many independent power supplies that must be floating, isolated, and balanced.
- In some particular levels of voltage, bidirectional power supplies are required, and the same happens when regenerative braking needs to be applied
- The direct relation between the number of levels and the voltage amplitude, which produce a loss of quality when the output voltage is reduced.
- Costly and complex topologies have to be implemented to get the isolated supplies.

2.3. Block Diagram

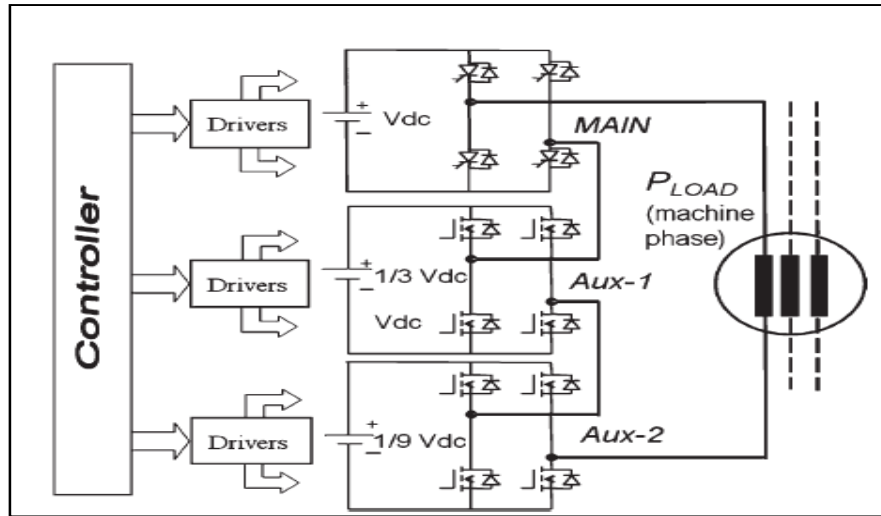

Figure 4: Main Components Of 27 Level Asymmetrical Type Multi Level Inverter For 1 Phase

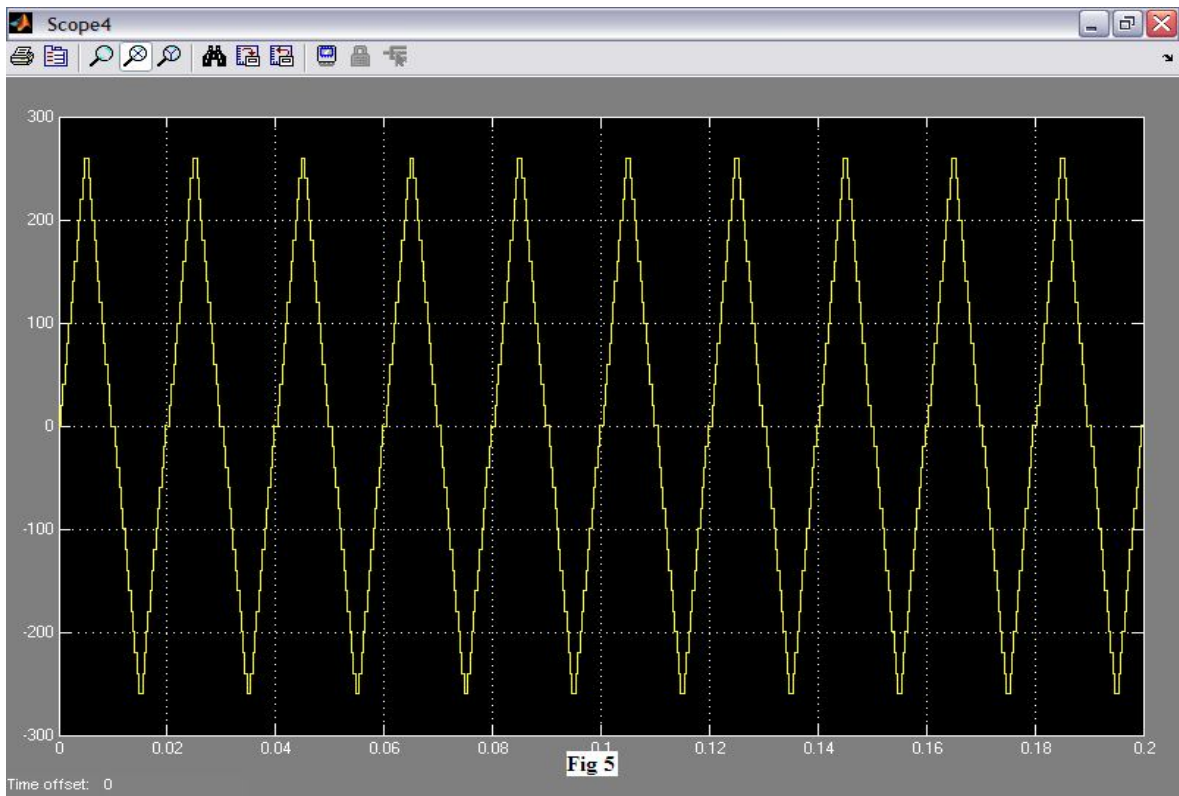

Figure 5

3. Methodology

Refer to Fig4 the voltage supplied to the 3 H-Bridge will be scaled in power 3 according to G.P ratio. The driver circuit will individually drive the gates of the MOSFET's connected in H-Bridge or optocoupler can be used in place of driver circuits.

All individual bridge is supplied by the d.c voltage which is multiple of 3 as shown in Figure.

The controller IC which generate the clock pulse will be programmed according to the phase delay we want in the clock pulse cycle and the duration we want of each clock pulse. Here the phase delay are providing as $0.02 * 1/56$ seconds. For one gate pulse i.e. in a graph paper if we will draw the gate waveform for each bridge then for 1cm block we are providing as $0.02 * 1/56$ seconds. The output we will get is shown in Fig5. The 3 outputs $V_{01}=1V_{dc}$, $V_{02}=3V_{dc}$, $V_{03}=9V_{dc}$ is showing the output of each bridge of the circuit and their total output after summation is 13Vdc waveform which is shown in Fig5. The maximum output voltage we will get is 13Vdc. It is called as 27 level output or 27 level symmetrical output.

Now if we will increase the level from 27 level to 81 level by increasing one more H-Bridge in Fig4. I.e. having $V_{01}=1V_{dc}$, $V_{02}=3V_{dc}$, $V_{03}=9V_{dc}$ and $V_{04}=27V_{dc}$ having same G.P ratio. As shown in Fig6. And the total output waveform is shown in Fig7.

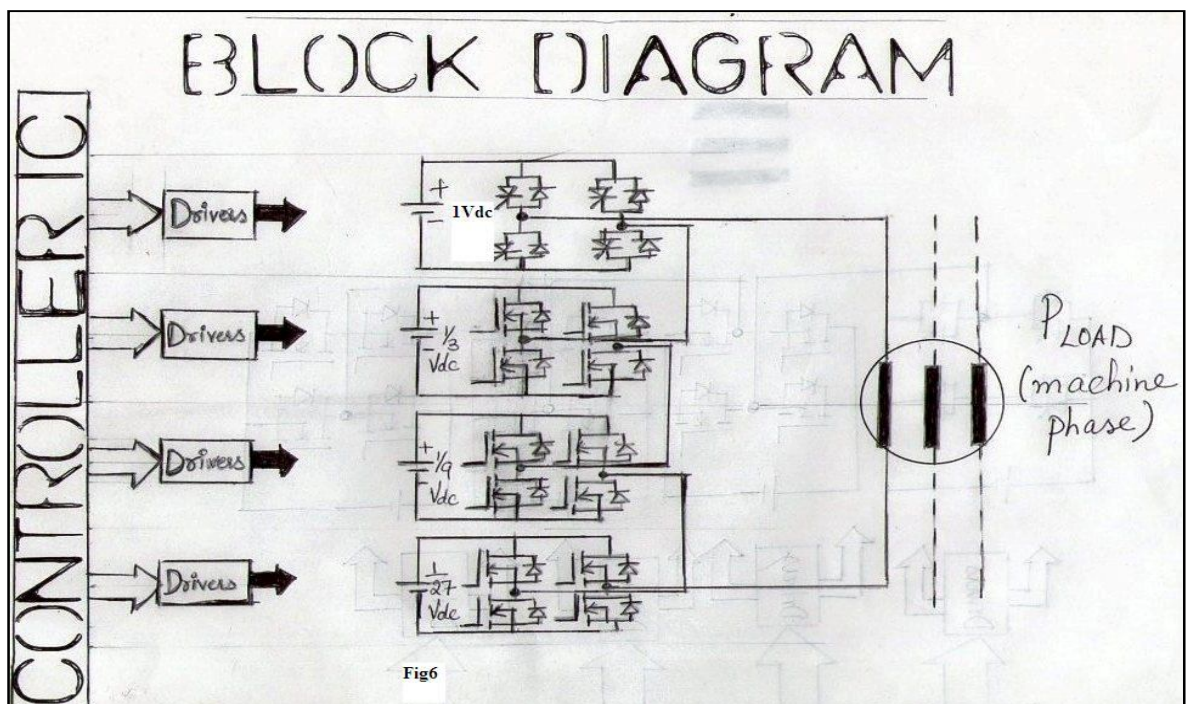

Figure 6

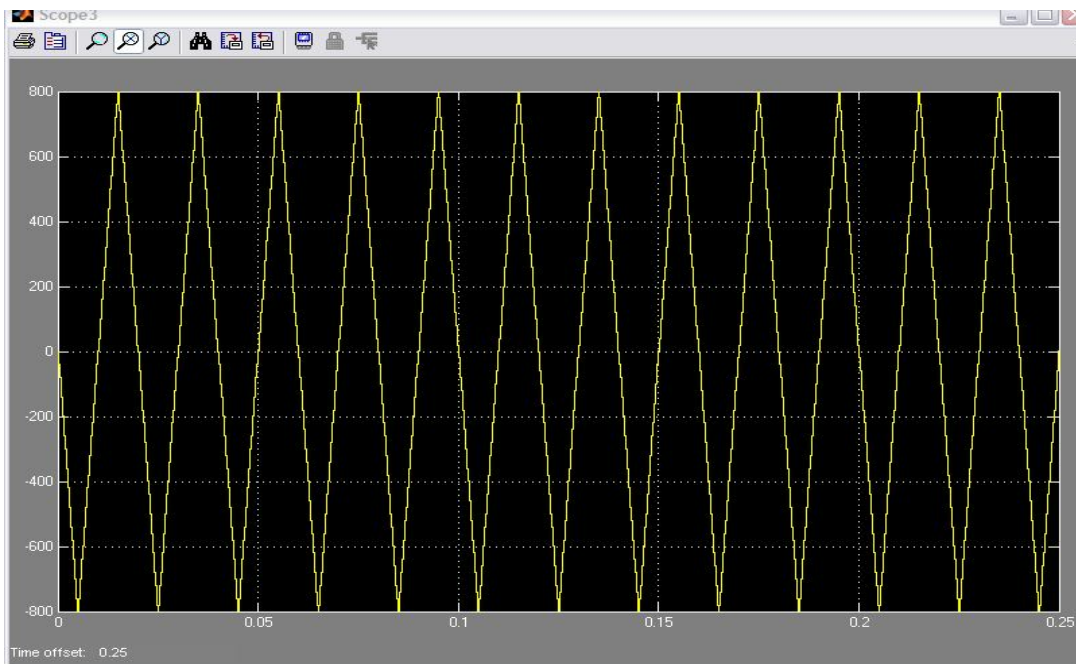

Figure7

From 81 level total output waveform we have seen that almost same output we are getting here as it was in 27 level case at the cost of limitations in 81 level circuitry. So it is not sensible to go upto higher level. The limitations with 81 level circuitry are as follows:

- Switching frequency of the bridge which shares the minimum power will increase.
- At the cost of the fourth bridge reduction in THD is not appreciable.
- Master Bridge(higher rating voltage bridge) will have to share the max. Power
- Distribution of power will not be uniform.
- Rating of the master bridge will be too high in comparison with the rating of the bridge which shares the minimum power.

4.Note

We are considering here G.P ratio as 3 instead of 2 because it Higher voltage output and higher level output.

5.Harmonic Effects On Induction Motor

Induction motors are commonly used in industry and sensitive to voltages harmonics and their operation and efficiency can be affected intensely their supplied power quality.

Some oscillations in three phase induction motors torque appear on launch time which these oscillations damped in very short time. Although the torque amount can be negative in that time but average value remain positive because of motors stable operation. If we use from speed-torque curve for depict of motor behavior in steady state. In every applications these oscillations will not be appreciable and can be negligible. In non sinusoidal supply conditions the oscillations existing in transient state is not damped and survive to steady state (with small value) which mainly leads to reduction of the efficiency of the motor. Various industrial loads including static converters (such as electric furnace, induction heating devices and switching power supply) inject current harmonics in power systems Generally power electronic devices such as switching source and converters are most important sources of harmonic generation. Converters usually generate harmonics from nth level in AC side.

$$n = knp \pm 1 \quad (2)$$

Where:

k is a constant and np is the number of converter pulses.

This phenomena lead to distortion in voltage like as iron saturation in over loaded distribution transformers. Induction motor under perfect sinusoidal supply condition generate little amount of current harmonics. Because of its coils structure and non linear behavior of iron core. Most important consequent of this phenomena is efficiency decrease of motor. Installation of capacitor placement in distribution systems for power factor correction and series reactor in transmission lines for decrease in short circuit current are not direct causes of harmonic generating but because of probability of resonance generation can intense and magnify existed harmonics. Voltage harmonic because of heat and oscillations produce in rotor cause most important damage to induction motor. Rotors oscillations are because of torque ripples and these ripples emerge from positive and negative ordinary harmonics. Rotors oscillations can increase friction losses of bearings. Since motors temperature in present of any harmonic would be higher than normal state and this will damage to bearings and stator coil and consequently motors life will be decreased. For preventing of excessive rise of motors temperature, motors should be derated. This derating leads to increase of energy consumption and cause more damages to consumers.

6. Conclusion

The Asymmetrical multilevel inverter topology is used for the optimization of levels with a minimum no. of voltage sources. It is used where medium voltage and higher power is required. A multilevel inverter is more advantageous in comparison with a conventional two-level converter that uses high switching frequency pulse width modulation (PWM). The increase in the number of levels in multilevel inverter reduces the total harmonic distortion (THD), common mode voltages, the output filters and the switching losses and hence power flow can be controlled by providing smooth a.c sine wave to the induction motor to mainly prevent the reduction of the efficiency of the motor due to harmonics which are present in normal power supply.

7.Reference

1. Bambang Sujanarko, Mochamad Ashari “Advanced Carrier Based Pulse Width Modulation in Asymmetric Cascaded Multilevel Inverter” International Journal of Electrical & Computer Sciences IJECS-IJENS Vol: 10 No: 06.
2. Diorge Alex Bao Zambra, Cassiano Rech and Jose Renes Pinheiro “COMPARISON AMONG THREE TOPOLOGIES OF MULTILEVEL INVERTERS”
3. Farid Khoucha, Mouna Soumia Lagoun, Abdelaziz Kheloui, and Mohamed El Hachemi Benbouzid “A Comparison of Symmetrical and Asymmetrical Three-Phase H-Bridge Multilevel Inverter for DTC Induction Motor Drives” IEEE Transactions On Energy Conversion, Vol. 26, No. 1, March 2011
4. Juan Dixon, Javier Pereda “Asymmetrical Multilevel Inverter for Traction Drives Using Only One DC Supply” IEEE Transactions On Vehicular Technology, Vol. 59, No. 8, October 2010